

**Features**

- **HIGH-DENSITY PROGRAMMABLE LOGIC**
  - 8000 PLD Gates
  - 96 I/O Pins, Ten Dedicated Inputs
  - 288 Registers
  - High-Speed Global Interconnects
  - Wide Input Gating for Fast Counters, State Machines, Address Decoders, etc.
  - Small Logic Block Size for Random Logic
  - Security Cell Prevents Unauthorized Copying
- **HIGH PERFORMANCE E<sup>2</sup>CMOS® TECHNOLOGY**
  - $f_{max} = 80$  MHz Maximum Operating Frequency
  - $f_{max} = 50$  MHz for Industrial Devices
  - $t_{pd} = 15$  ns Propagation Delay
  - TTL Compatible Inputs and Outputs
  - Electrically Erasable and Reprogrammable
  - Non-Volatile E<sup>2</sup>CMOS Technology
  - 100% Tested
- **ispLSI OFFERS THE FOLLOWING ADDED FEATURES**
  - In-System Programmable™ (ISP™) 5-Volt Only
  - Increased Manufacturing Yields, Reduced Time-to-Market, and Improved Product Quality
  - Reprogram Soldered Devices for Faster Debugging
- **COMBINES EASE OF USE AND THE FAST SYSTEM SPEED OF PLDs WITH THE DENSITY AND FLEXIBILITY OF FIELD PROGRAMMABLE GATE ARRAYS**
  - Complete Programmable Device Can Combine Glue Logic and Structured Designs
  - Four Dedicated Clock Input Pins
  - Synchronous and Asynchronous Clocks
  - Flexible Pin Placement
  - Optimized Global Routing Pool Provides Global Interconnectivity
- **ispEXPERT™ – LOGIC COMPILER AND COMPLETE ISP DEVICE DESIGN SYSTEMS FROM HDL SYNTHESIS THROUGH IN-SYSTEM PROGRAMMING**
  - Superior Quality of Results
  - Tightly Integrated with Leading CAE Vendor Tools
  - Productivity Enhancing Timing Analyzer, Explore Tools, Timing Simulator and ispANALYZER™
  - PC and UNIX Platforms

**Functional Block Diagram**

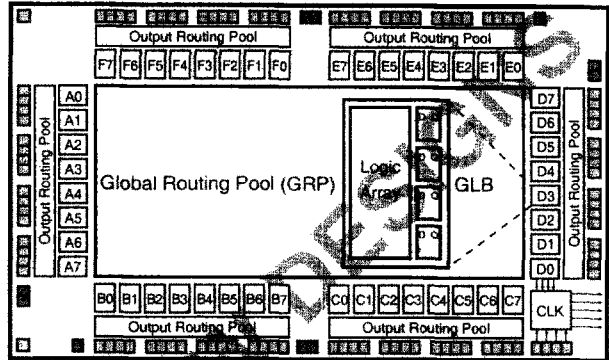

**Description**

The ispLSI and pLSI 1048 are High-Density Programmable Logic Devices which contain 288 Registers, 96 Universal I/O pins, ten Dedicated Input pins, four Dedicated Clock Input pins and a Global Routing Pool (GRP). The GRP provides complete interconnectivity between all of these elements. The ispLSI 1048 features 5-Volt in-system programming and in-system diagnostic capabilities. It is the first device which offers non-volatile reprogrammability of the logic, as well as the interconnect to provide truly reconfigurable systems. It is architecturally and parametrically compatible to the pLSI 1048 device, but multiplexes four of the dedicated input pins to control in-system programming.

The basic unit of logic on the ispLSI and pLSI 1048 devices is the Generic Logic Block (GLB). The GLBs are labeled A0, A1 .. F7 (see figure 1). There are a total of 48 GLBs in the ispLSI and pLSI 1048 devices. Each GLB has 18 inputs, a programmable AND/OR/XOR array, and four outputs which can be configured to be either combinatorial or registered. Inputs to the GLB come from the GRP and dedicated inputs. All of the GLB outputs are brought back into the GRP so that they can be connected to the inputs of any other GLB on the device.

Copyright © 1998 Lattice Semiconductor Corp. All brand or product names are trademarks or registered trademarks of their respective holders. The specifications and information herein are subject to change without notice.

**Functional Block Diagram**

Figure 1. ispLSI and pLSI 1048 Functional Block Diagram

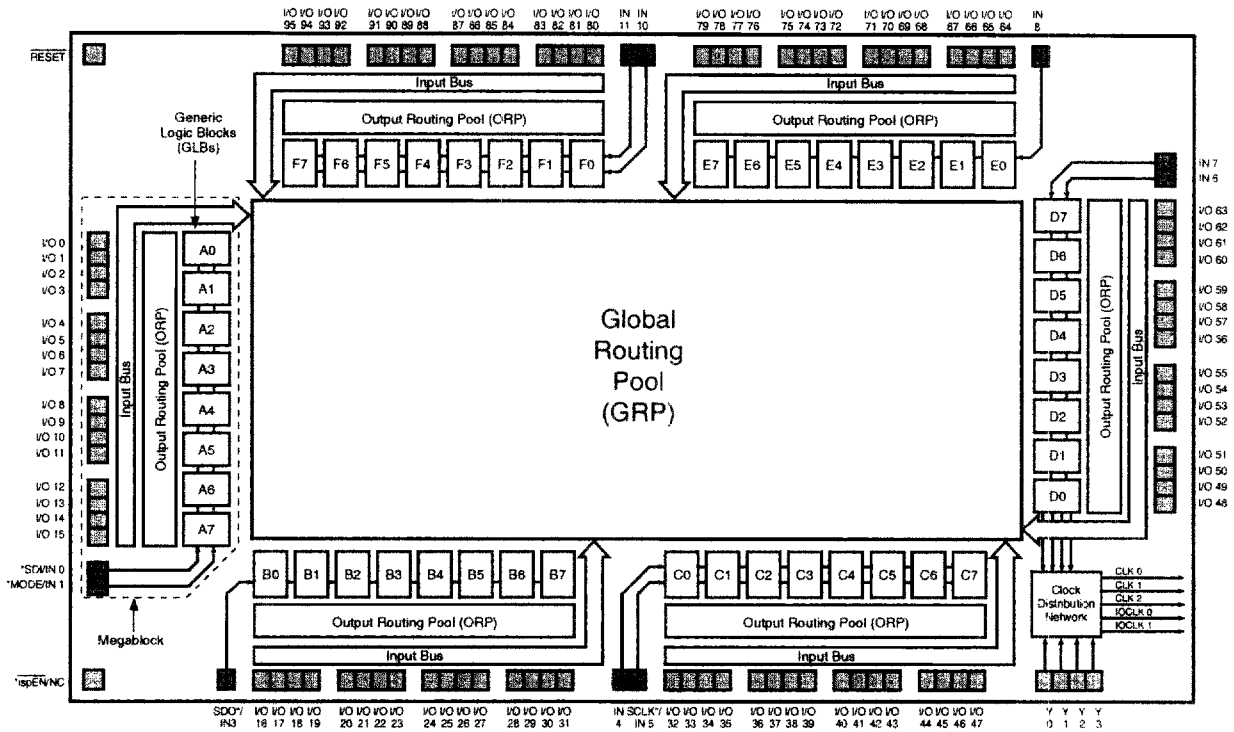

\*ISP Control Functions for ispLSI 1048 Only

0139F(1)-48-isp

The devices also have 96 I/O cells, each of which is directly connected to an I/O pin. Each I/O cell can be individually programmed to be a combinatorial input, registered input, latched input, output or bi-directional I/O pin with 3-state control. Additionally, all outputs are polarity selectable, active high or active low. The signal levels are TTL compatible voltages and the output drivers can source 4 mA or sink 8 mA.

Eight GLBs, 16 I/O cells, two dedicated inputs (one dedicated input in Megablock B and E) and one ORP are connected together to make a Megablock (see figure 1). The outputs of the eight GLBs are connected to a set of 16 universal I/O cells by the ORP. The ispLSI and pLSI 1048 devices contain six of these Megablocks.

The GRP has as its inputs the outputs from all of the GLBs and all of the inputs from the bi-directional I/O cells. All of these signals are made available to the inputs of the GLBs. Delays through the GRP have been equalized to minimize timing skew.

Clocks in the ispLSI and pLSI 1048 devices are selected using the Clock Distribution Network. Four dedicated clockpins (Y0, Y1, Y2 and Y3) are brought into the distribution network, and five clock outputs (CLK 0, CLK 1, CLK 2, IOCLK 0 and IOCLK 1) are provided to route clocks to the GLBs and I/O cells. The Clock Distribution Network can also be driven from a special clock GLB (D0 on the ispLSI and pLSI 1048 devices). The logic of this GLB allows the user to create an internal clock from a combination of internal signals within the device.

## Absolute Maximum Ratings <sup>1</sup>

Supply Voltage  $V_{CC}$  ..... -0.5 to +7.0V  
 Input Voltage Applied ..... -2.5 to  $V_{CC} + 1.0V$   
 Off-State Output Voltage Applied ..... -2.5 to  $V_{CC} + 1.0V$   
 Storage Temperature ..... -65 to 150°C  
 Case Temp. with Power Applied ..... -55 to 125°C  
 Max. Junction Temp. ( $T_J$ ) with Power Applied ... 150°C

1. Stresses above those listed under the "Absolute Maximum Ratings" may cause permanent damage to the device. Functional operation of the device at these or at any other conditions above those indicated in the operational sections of this specification is not implied (while programming, follow the programming specifications).

## DC Recommended Operating Conditions

SYMBOL	PARAMETER	MIN.	MAX.	UNITS	
$V_{CC}$	Supply Voltage	Commercial $T_A = 0^\circ C$ to $+70^\circ C$	4.75	5.25	V
		Industrial $T_A = -40^\circ C$ to $+85^\circ C$	4.5	5.5	
$V_{IL}$	Input Low Voltage	0	0.8	V	
$V_{IH}$	Input High Voltage	2.0	$V_{CC} + 1$	V	

## Capacitance ( $T_A = 25^\circ C$ , $f = 1.0$ MHz)

SYMBOL	PARAMETER	MAXIMUM <sup>1</sup>	UNITS	TEST CONDITIONS
$C_1$	Dedicated Input Capacitance	8	pf	$V_{CC} = 5.0V$ , $V_{IN} = 2.0V$
$C_2$	I/O and Clock Capacitance	10	pf	$V_{CC} = 5.0V$ , $V_{I/O}$ , $V_Y = 2.0V$

1. Guaranteed but not 100% tested.

## Data Retention Specifications

PARAMETER	MINIMUM	MAXIMUM	UNITS
Data Retention	20	–	Years
ispLSI Erase/Reprogram Cycles	10000	–	Cycles
pLSI Erase/Reprogram Cycles	100	–	Cycles

Table 2- 0008B

**Switching Test Conditions**

Input Pulse Levels	GND to 3.0V
Input Rise and Fall Time	≤ 3ns 10% to 90%
Input Timing Reference Levels	1.5V
Output Timing Reference Levels	1.5V
Output Load	See figure 2

3-state levels are measured 0.5V from steady-state active level.

Table 2-0003

**Output Load Conditions (see figure 2)**

Test Condition	R1	R2	CL
A	470Ω	390Ω	35pF
B	Active High	∞	390Ω
	Active Low	470Ω	390Ω
C	Active High to Z at $V_{OH} - 0.5V$	∞	390Ω
	Active Low to Z at $V_{OL} + 0.5V$	470Ω	390Ω

**Figure 2. Test Load**

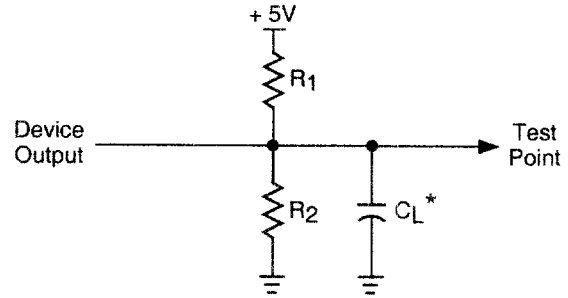

\*CL includes Test Fixture and Probe Capacitance.

**DC Electrical Characteristics**

**Over Recommended Operating Conditions**

SYMBOL	PARAMETER	CONDITION	MIN.	TYP. <sup>3</sup>	MAX.	UNITS	
VOL	Output Low Voltage	$I_{OL} = 8 \text{ mA}$	-	-	0.4	V	
VOH	Output High Voltage	$I_{OH} = -4 \text{ mA}$	2.4	-	-	V	
IIL	Input or I/O Low Leakage Current	$0V \leq V_{IN} \leq V_{IL} \text{ (MAX.)}$	-	-	-10	μA	
IIH	Input or I/O High Leakage Current	$3.5V \leq V_{IN} \leq V_{CC}$	-	-	10	μA	
IIL-isp	isp Input Low Leakage Current	$0V \leq V_{IN} \leq V_{IL} \text{ (MAX.)}$	-	-	-150	μA	
IIL-PU	I/O Active Pull-Up Current	$0V \leq V_{IN} \leq V_{IL}$	-	-	-150	μA	
IOS1	Output Short Circuit Current	$V_{CC} = 5V, V_{OUT} = 0.5V$	-	-	-200	mA	
ICC2,4	Operating Power Supply Current	$V_{IL} = 0.5V, V_{IH} = 3.0V$	Commercial	-	165	235	mA
		$f_{TOGGLE} = 1 \text{ MHz}$	Industrial	-	165	260	mA

- One output at a time for a maximum duration of one second.  $V_{OUT} = 0.5V$  was selected to avoid test problems by tester ground degradation. Characterized but not 100% tested.
- Measured using twelve 16-bit counters.
- Typical values are at  $V_{CC} = 5V$  and  $T_A = 25^\circ C$ .
- Maximum  $I_{CC}$  varies widely with specific device configuration and operating frequency. Refer to the Power Consumption section of this datasheet and Thermal Management section of this Lattice Semiconductor Data Book or CD-ROM to estimate maximum  $I_{CC}$ .

Table 2-0007A-4B-isp

## External Timing Parameters

### Over Recommended Operating Conditions

PARAMETER	TEST <sup>5</sup> COND.	# <sup>2</sup>	DESCRIPTION <sup>1</sup>	-80		-70		-50		UNITS
				MIN.	MAX.	MIN.	MAX.	MIN.	MAX.	
t <sub>pd1</sub>	A	1	Data Propagation Delay, 4PT bypass, ORP bypass	-	15	-	18	-	24	ns
t <sub>pd2</sub>	A	2	Data Propagation Delay, Worst Case Path	-	20	-	23	-	30.7	ns
f <sub>max</sub> (Int.)	A	3	Clock Frequency with Internal Feedback <sup>3</sup>	80	-	71.4	-	53.1	-	MHz
f <sub>max</sub> (Ext.)	-	4	Clock Frequency with External Feedback $\left(\frac{1}{t_{su2} + t_{co1}}\right)$	50	-	41.7	-	31.3	-	MHz
f <sub>max</sub> (Tog.)	-	5	Clock Frequency, Max Toggle <sup>4</sup>	100	-	83	-	71.4	-	MHz
t <sub>su1</sub>	-	6	GLB Reg. Setup Time before Clock, 4PT bypass	7	-	9	-	12	-	ns
t <sub>co1</sub>	A	7	GLB Reg. Clock to Output Delay, ORP bypass	-	10	-	12	-	16	ns
t <sub>h1</sub>	-	8	GLB Reg. Hold Time after Clock, 4 PT bypass	0	-	0	-	0	-	ns
t <sub>su2</sub>	-	9	GLB Reg. Setup Time before Clock	10	-	12	-	16	-	ns
t <sub>co2</sub>	-	10	GLB Reg. Clock to Output Delay	-	12	-	14	-	18.7	ns
t <sub>h2</sub>	-	11	GLB Reg. Hold Time after Clock	0	-	0	-	0	-	ns
t <sub>r1</sub>	A	12	Ext. Reset Pin to Output Delay	-	17	-	17	-	22.7	ns
t <sub>rw1</sub>	-	13	Ext. Reset Pulse Duration	10	-	10	-	13	-	ns
t <sub>en</sub>	B	14	Input to Output Enable	-	18	-	20	-	26.7	ns
t <sub>dis</sub>	C	15	Input to Output Disable	-	18	-	20	-	26.7	ns
t <sub>wh</sub>	-	16	Ext. Sync. Clock Pulse Duration, High	5	-	6	-	7	-	ns
t <sub>wl</sub>	-	17	Ext. Sync. Clock Pulse Duration, Low	5	-	6	-	7	-	ns
t <sub>su5</sub>	-	18	I/O Reg. Setup Time before Ext. Sync. Clock (Y2, Y3)	2	-	2	-	2.7	-	ns
t <sub>h5</sub>	-	19	I/O Reg. Hold Time after Ext. Sync. Clock (Y2, Y3)	6.5	-	6.5	-	8.7	-	ns

1. Unless noted otherwise, all parameters use a GRP load of 4 GLBs, 20 PTXOR path, ORP and Y0 clock.
2. Refer to Timing Model in this data sheet for further details.
3. Standard 16-Bit loadable counter using GRP feedback.
4. f<sub>max</sub> (Toggle) may be less than 1/(t<sub>wh</sub> + t<sub>wl</sub>). This is to allow for a clock duty cycle of other than 50%.
5. Reference Switching Test Conditions section.

Table 2- 0030A-48/80,70,50

## Internal Timing Parameters<sup>1</sup>

PARAMETER	# <sup>2</sup>	DESCRIPTION	-80		-70		-50		UNITS
			MIN.	MAX.	MIN.	MAX.	MIN.	MAX.	
<b>Inputs</b>									
t <sub>iobp</sub>	20	I/O Register Bypass	-	2.5	-	3.0	-	4.0	ns
t <sub>iolat</sub>	21	I/O Latch Delay	-	3.3	-	4.0	-	5.3	ns
t <sub>iosu</sub>	22	I/O Register Setup Time before Clock	5.3	-	6.0	-	8.0	-	ns
t <sub>ioh</sub>	23	I/O Register Hold Time after Clock	1.5	-	0.5	-	0.9	-	ns
t <sub>ioco</sub>	24	I/O Register Clock to Out Delay	-	2.5	-	3.0	-	3.9	ns
t <sub>ior</sub>	25	I/O Register Reset to Out Delay	-	2.9	-	3.5	-	4.6	ns
t <sub>din</sub>	26	Dedicated Input Delay	-	5.0	-	6.0	-	8.0	ns
<b>GRP</b>									
t <sub>grp1</sub>	27	GRP Delay, 1 GLB Load	-	2.1	-	2.5	-	3.3	ns
t <sub>grp4</sub>	28	GRP Delay, 4 GLB Loads	-	2.5	-	3.0	-	4.0	ns
t <sub>grp8</sub>	29	GRP Delay, 8 GLB Loads	-	3.3	-	4.0	-	5.3	ns
t <sub>grp12</sub>	30	GRP Delay, 12 GLB Loads	-	4.2	-	5.0	-	6.7	ns
t <sub>grp16</sub>	31	GRP Delay, 16 GLB Loads	-	5.0	-	6.0	-	8.0	ns
t <sub>grp48</sub>	32	GRP Delay, 48 GLB Loads	-	13.3	-	16.0	-	21.3	ns
<b>GLB</b>									
t <sub>4ptbp</sub>	33	4 Product Term Bypass Path Delay	-	5.4	-	6.5	-	8.6	ns
t <sub>1ptxor</sub>	34	1 Product Term/XOR Path Delay	-	6.5	-	7.0	-	9.3	ns
t <sub>20ptxor</sub>	35	20 Product Term/XOR Path Delay	-	7.6	-	7.5	-	10.0	ns
t <sub>xoradj</sub>	36	XOR Adjacent Path Delay <sup>3</sup>	-	8.4	-	9.5	-	12.7	ns
t <sub>gbp</sub>	37	GLB Register Bypass Delay	-	0.8	-	1.0	-	1.3	ns
t <sub>gsu</sub>	38	GLB Register Setup Time before Clock	0.8	-	1.5	-	2.0	-	ns
t <sub>gh</sub>	39	GLB Register Hold Time after Clock	5.0	-	6.0	-	8.0	-	ns
t <sub>gco</sub>	40	GLB Register Clock to Output Delay	-	2.1	-	2.5	-	3.3	ns
t <sub>gr</sub>	41	GLB Register Reset to Output Delay	-	2.1	-	2.5	-	3.3	ns
t <sub>ptre</sub>	42	GLB Product Term Reset to Register Delay	-	8.3	-	10.0	-	13.3	ns
t <sub>ptoe</sub>	43	GLB Product Term Output Enable to I/O Cell Delay	-	8.8	-	9.0	-	11.9	ns
t <sub>ptck</sub>	44	GLB Product Term Clock Delay	2.9	6.3	3.5	7.5	4.6	9.9	ns
<b>ORP</b>									
t <sub>orp</sub>	45	ORP Delay	-	3.2	-	3.5	-	4.7	ns
t <sub>orpbp</sub>	46	ORP Bypass Delay	-	1.3	-	1.5	-	2.0	ns

1. Internal Timing Parameters are not tested and are for reference only.
2. Refer to Timing Model in this data sheet for further details.
3. The XOR adjacent path can only be used by hard macros.

Table 2- 0036A-48/80,70,50 eps

## Internal Timing Parameters<sup>1</sup>

PARAMETER	# <sup>2</sup>	DESCRIPTION	-80		-70		-50		UNITS
			MIN.	MAX.	MIN.	MAX.	MIN.	MAX.	
<b>Outputs</b>									
t <sub>ob</sub>	47	Output Buffer Delay	–	2.5	–	3.0	–	4.0	ns
t <sub>oen</sub>	48	I/O Cell OE to Output Enabled	–	4.2	–	5.0	–	6.7	ns
t <sub>odis</sub>	49	I/O Cell OE to Output Disabled	–	4.2	–	5.0	–	6.7	ns
<b>Clocks</b>									
t <sub>gy0</sub>	50	Clock Delay, Y0 to Global GLB Clock Line (Ref. clock)	4.2	4.2	5.0	6.0	6.7	6.7	ns
t <sub>gy1/2</sub>	51	Clock Delay, Y1 or Y2 to Global GLB Clock Line	3.3	5.0	4.0	6.0	5.3	8.0	ns
t <sub>gcp</sub>	52	Clock Delay, Clock GLB to Global GLB Clock Line	0.8	4.2	1.0	5.0	1.3	6.6	ns
t <sub>ioy2/3</sub>	53	Clock Delay, Y2 or Y3 to I/O Cell Global Clock Line	3.3	5.0	4.0	6.0	5.3	8.0	ns
t <sub>iocp</sub>	54	Clock Delay, Clock GLB to I/O Cell Global Clock Line	0.8	4.2	1.0	5.0	1.3	6.6	ns
<b>Global Reset</b>									
t <sub>gr</sub>	55	Global Reset to GLB and I/O Registers	–	9.2	–	8.0	–	10.6	ns

1. Internal Timing Parameters are not tested and are for reference only.
2. Refer to Timing Model in this data sheet for further details.

**ispLSI and pLSI 1048 Timing Model**

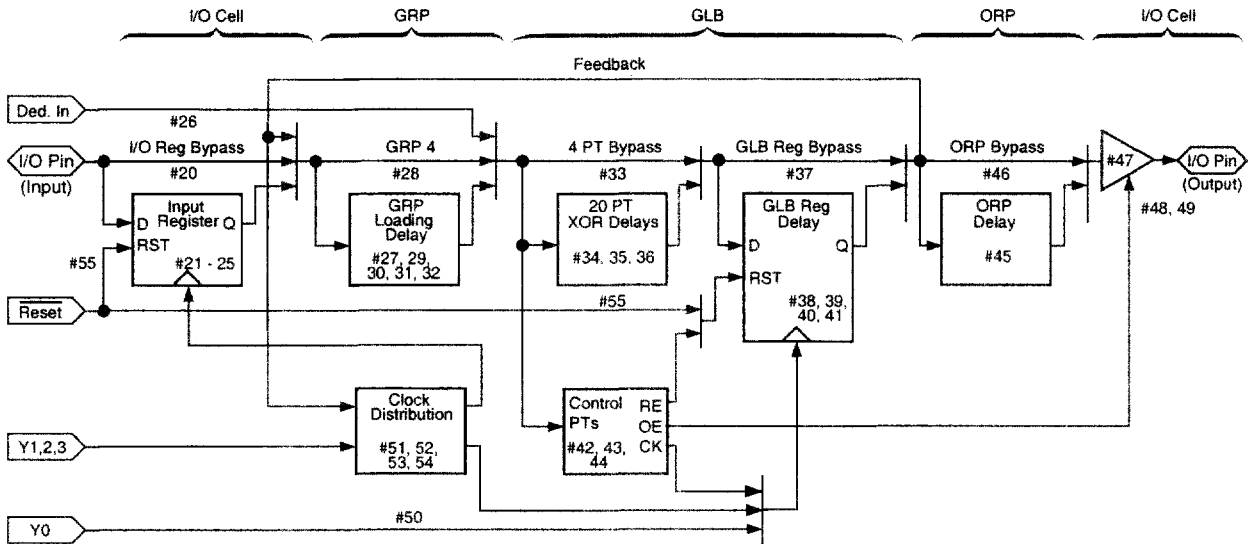

**Derivations of  $t_{su}$ ,  $t_h$  and  $t_{co}$  from the Product Term Clock<sup>1</sup>**

$$\begin{aligned}
 t_{su} &= \text{Logic} + \text{Reg } s_u - \text{Clock (min)} \\
 &= (t_{iobp} + t_{grp4} + t_{20ptxor}) + (t_{gsu}) - (t_{iobp} + t_{grp4} + t_{ptck(min)}) \\
 &= (\#20 + \#28 + \#35) + (\#38) - (\#20 + \#28 + \#44) \\
 5.5 \text{ ns} &= (3.0 + 3.0 + 7.5) + (1.5) - (3.0 + 3.0 + 3.5) \\
 t_h &= \text{Clock (max)} + \text{Reg } h - \text{Logic} \\
 &= (t_{iobp} + t_{grp4} + t_{ptck(max)}) + (t_{gh}) - (t_{iobp} + t_{grp4} + t_{20ptxor}) \\
 &= (\#20 + \#28 + \#44) + (\#39) - (\#20 + \#28 + \#35) \\
 6.0 \text{ ns} &= (3.0 + 3.0 + 7.5) + (6.0) - (3.0 + 3.0 + 7.5) \\
 t_{co} &= \text{Clock (max)} + \text{Reg } c_o + \text{Output} \\
 &= (t_{iobp} + t_{grp4} + t_{ptck(max)}) + (t_{gco}) + (t_{orp} + t_{ob}) \\
 &= (\#20 + \#28 + \#44) + (\#40) + (\#45 + \#47) \\
 22.5 \text{ ns} &= (3.0 + 3.0 + 7.5) + (2.5) + (3.5 + 3.0)
 \end{aligned}$$

**Derivations of  $t_{su}$ ,  $t_h$  and  $t_{co}$  from the Clock GLB<sup>1</sup>**

$$\begin{aligned}
 t_{su} &= \text{Logic} + \text{Reg } s_u - \text{Clock (min)} \\
 &= (t_{iobp} + t_{grp4} + t_{20ptxor}) + (t_{gsu}) - (t_{gy0(min)} + t_{gco} + t_{gcp(min)}) \\
 &= (\#20 + \#28 + \#35) + (\#38) - (\#50 + \#40 + \#52) \\
 6.5 \text{ ns} &= (3.0 + 3.0 + 7.5) + (1.5) - (5.0 + 2.5 + 1.0) \\
 t_h &= \text{Clock (max)} + \text{Reg } h - \text{Logic} \\
 &= (t_{gy0(max)} + t_{gco} + t_{gcp(max)}) + (t_{gh}) - (t_{iobp} + t_{grp4} + t_{20ptxor}) \\
 &= (\#50 + \#40 + \#52) + (\#39) - (\#20 + \#28 + \#35) \\
 5.0 \text{ ns} &= (5.0 + 2.5 + 5.0) + (6.0) - (3.0 + 3.0 + 7.5) \\
 t_{co} &= \text{Clock (max)} + \text{Reg } c_o + \text{Output} \\
 &= (t_{gy0(max)} + t_{gco} + t_{gcp(max)}) + (t_{gco}) + (t_{orp} + t_{ob}) \\
 &= (\#50 + \#40 + \#52) + (\#40) + (\#45 + \#47) \\
 21.5 \text{ ns} &= (5.0 + 2.5 + 5.0) + (2.5) + (3.5 + 3.0)
 \end{aligned}$$

1. Calculations are based upon timing specifications for the ispLSI and pLSI 1048-70.



**Maximum GRP Delay vs GLB Loads**

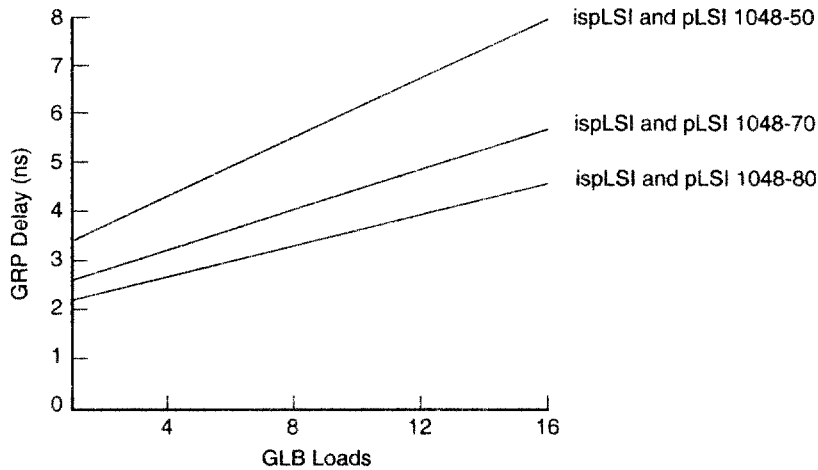

0126A-48-80-isp

**Power Consumption**

Power consumption in the ispLSI and pLSI 1048 device depends on two primary factors: the speed at which the device is operating, and the number of Product Terms used. Figure 3 shows the relationship between power and operating speed.

**Figure 3. Typical Device Power Consumption vs fmax**

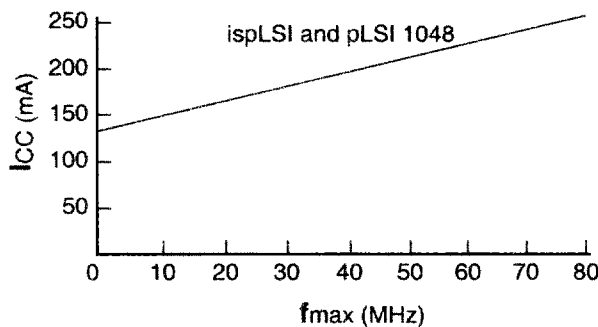

Notes: Configuration of Twelve 16-bit Counters  
Typical Current at 5V, 25°C

ICC can be estimated for the ispLSI and pLSI 1048 using the following equation:

$$I_{CC} = 73 + (\# \text{ of PTs} * 0.23) + (\# \text{ of nets} * \text{Max. freq} * 0.010) \text{ where:}$$

# of PTs = Number of Product Terms used in design

# of nets = Number of Signals used in device

Max. freq = Highest Clock Frequency to the device

The ICC estimate is based on typical conditions (VCC = 5.0V, room temperature) and an assumption of 2 GLB loads on average exists. These values are for estimates only. Since the value of ICC is sensitive to operating conditions and the program in the device, the actual ICC should be verified.

0127A-48-80-isp

## Pin Description

NAME	PQFP PIN NUMBERS	DESCRIPTION
I/O 0 - I/O 5 I/O 6 - I/O 11 I/O 12 - I/O 17 I/O 18 - I/O 23 I/O 24 - I/O 29 I/O 30 - I/O 35 I/O 36 - I/O 41 I/O 42 - I/O 47 I/O 48 - I/O 53 I/O 54 - I/O 59 I/O 60 - I/O 65 I/O 66 - I/O 71 I/O 72 - I/O 77 I/O 78 - I/O 83 I/O 84 - I/O 89 I/O 90 - I/O 95	20, 21, 22, 23, 24, 25, 26, 27, 28, 29, 30, 31, 32, 33, 34, 35, 36, 37, 38, 39, 40, 41, 42, 43, 49, 50, 51, 52, 53, 54, 55, 56, 57, 58, 59, 60, 61, 62, 63, 64, 65, 66, 67, 68, 69, 70, 71, 72, 80, 81, 82, 83, 84, 85, 86, 87, 88, 89, 90, 91, 92, 93, 94, 95, 96, 97, 98, 99, 100, 101, 102, 103, 109, 110, 111, 112, 113, 114, 115, 116, 117, 118, 119, 120, 1, 2, 3, 4, 5, 6, 7, 8, 9, 10, 11, 12	Input/Output Pins - These are the general purpose I/O pins used by the logic array.
IN 4 IN 6 - IN 11	48, 79, 104, 105, -- 108, 13	Dedicated input pins to the device. (IN 2 and IN 9 not available)
$\overline{\text{ispEN}}/\text{NC}^{1, 2}$	17	Input – Dedicated in-system programming enable input pin. This pin is brought low to enable the programming mode. The MODE, SDI, SDO and SCLK options become active.
SDI/IN 0 <sup>2</sup>	19	Input – This pin performs two functions. It is a dedicated input pin when $\overline{\text{ispEN}}$ is logic high. When $\overline{\text{ispEN}}$ is logic low, it functions as an input pin to load programming data into the device. SDI/IN 0 also is used as one of the two control pins for the isp state machine.
MODE/IN 1 <sup>2</sup>	44	Input – This pin performs two functions. It is a dedicated input pin when $\overline{\text{ispEN}}$ is logic high. When $\overline{\text{ispEN}}$ is logic low, it functions as a pin to control the operation of the isp state machine.
SDO/IN 3 <sup>2</sup>	47	Input/Output – This pin performs two functions. It is a dedicated input pin when $\overline{\text{ispEN}}$ is logic high. When $\overline{\text{ispEN}}$ is logic low, it functions as an output pin to read serial shift register data.
SCLK/IN 5 <sup>2</sup>	73	Input – This pin performs two functions. It is a dedicated input when $\overline{\text{ispEN}}$ is logic high. When $\overline{\text{ispEN}}$ is logic low, it functions as a clock pin for the Serial Shift Register.
$\overline{\text{RESET}}$	18	Active Low (0) Reset pin which resets all of the GLB and I/O registers in the device.
Y0	14	Dedicated Clock input. This clock input is connected to one of the clock inputs of all of the GLBs on the device.
Y1	78	Dedicated clock input. This clock input is brought into the clock distribution network, and can optionally be routed to any GLB on the device.
Y2	75	Dedicated clock input. This clock input is brought into the clock distribution network, and can optionally be routed to any GLB and/or any I/O cell on the device.
Y3	74	Dedicated clock input. This clock input is brought into the clock distribution network, and can optionally be routed to any I/O cell on the device.
GND V <sub>CC</sub>	46, 76, 106, 16 15, 45, 77, 107	Ground (GND) V <sub>CC</sub>

1. NC pins are not to be connected to any active signals, V<sub>CC</sub>, or GND.

2. Pins have dual function capability for ispLSI 1048 only.



**Part Number Description**

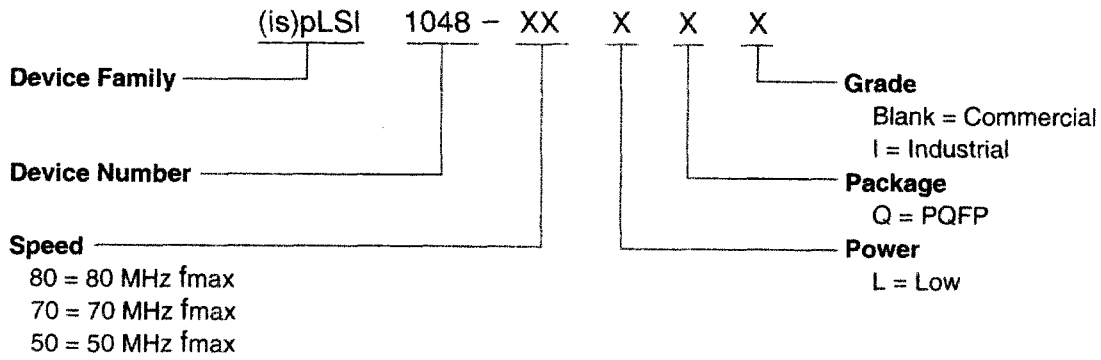

0212-80B-isp1048

**ispLSI and pLSI 1048 Ordering Information**

**COMMERCIAL**

Family	fmax (MHz)	tpd (ns)	Ordering Number	Package
ispLSI	80	15	ispLSI 1048-80LQ	120-Pin PQFP
	70	18	ispLSI 1048-70LQ	120-Pin PQFP
	50	24	ispLSI 1048-50LQ	120-Pin PQFP
pLSI	80	15	pLSI 1048-80LQ	120-Pin PQFP
	70	18	pLSI 1048-70LQ	120-Pin PQFP
	50	24	pLSI 1048-50LQ	120-Pin PQFP

**INDUSTRIAL**

Family	fmax (MHz)	tpd (ns)	Ordering Number	Package
ispLSI	50	24	ispLSI 1048-50LQI	120-Pin PQFP
pLSI	50	24	pLSI 1048-50LQI	120-Pin PQFP

Table 2-0041A-48-isp